

CorExtend™ capability
allows SoC designers
to add instructions
to create more
competitive products

MIPS Technologies Pro Series® cores with the CorExtend capability enable SoC designers to supercharge SoC performance and optimize their products in ways that aren't possible with standard cores.

MIPS Pro Series®

Pro Series® cores offer unprecedented value by enabling SoC designers to write their own instruction set extensions and create highly differentiated, highly competitive products. Using standard tools and software, designers can implement instruction extensions to significantly increase performance, reduce power consumption, implement critical operations and more.

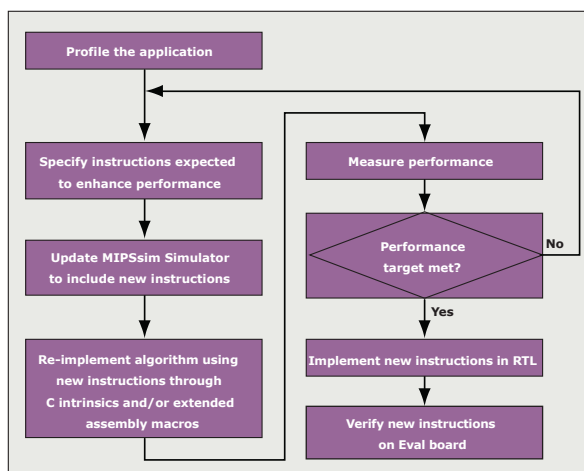

Implementation of CorExtend™ instruction extensions with the Pro Series® cores is straightforward and fully supported by a range of development tools. The instruction extensions can be implemented in Verilog, so there is no need to learn a new proprietary development language. Tools support the CorExtend feature as intrinsics, so new instructions can be added or changed quickly in the security and privacy of your office or lab.

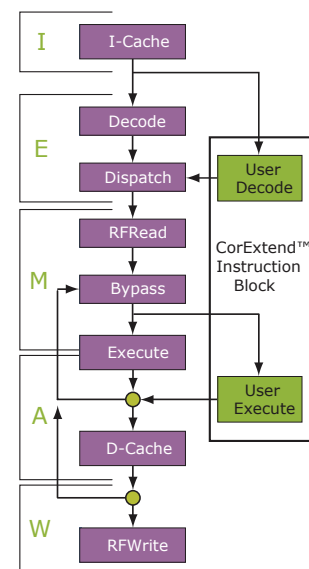

MIPS Pro Series Highlights

- Pro Series cores are based on the MIPS industry-standard architecture, which is supported by a broad range of standard tools and software that lowers development cost, reduces engineering risk, and accelerates time-to-market.
- The Pro Series processor core family features the CorExtend™ capability that allows SoC designers to add proprietary instructions and tightly coupled hardware.
- The CorExtend capability enables users to significantly enhance the value and competitive advantage of their SoC products.
- Previously only available to MIPS® architecture licensees, CorExtend instruction extensions can be used to implement critical operations, significantly improve application performance, reduce power consumption, reduce cost, eliminate the need for a coprocessor and reduce processing time.
- The Pro Series family's CorExtend capability gives the designer full access to read and write the general purpose registers. Both single- and multiple-cycle instructions are supported.
- CoWare's CORXpert™ Personality Kit for the 24K™, 24KE™ and 34K™ Pro Series cores allows users to rapidly develop extensions that optimize processor performance for a targeted application.

Pro Series® Cores

The Pro Series family consists of the MIPS32® 4KE™ Pro family, the MIPS32 M4K™ Pro core, the MIPS32 4KSd™ Pro core, the MIPS32 24K™ Pro family of cores, the MIPS32 24KE™ core family and the new MIPS32 34K™ Pro cores.

The 4KE Pro family builds upon the successful 4KE family with added CorExtend features to enhance application performance. The 4KE family is targeted at cost effective system implementations with MIPS16e™ code compression and other configuration options.

The M4K Pro core adds the CorExtend capability to this flexible, high-performance, yet surprisingly small and low-power core that offers the highest performance density of any 32-bit synthesizable core. Designers can meet the high system throughput demands of multi-CPU SoCs while controlling silicon costs.

The 4KSd Pro core is a superior solution for ensuring secure data communication in a variety of applications, such as networking, smart cards and set-top boxes. It includes the industry-standard SmartMIPS® architecture, which speeds software cryptography, eliminates the need for a coprocessor and has special instructions that reduce power consumption and die size.

The 24K Pro family offers the highest performance synthesizable, 32-bit processor for embedded applications. With optimal floating-point-unit and shared core resources, CorExtend can further enhance total system performance. The additional DSP functionality offered by the 24KE Pro family targets key applications from voice to video.

The MIPS 34K core family is a revolutionary multi-threading solution for highperformance, cost-sensitive embedded applications. Implementing the MIPS® MT ASE, it processes multiple software threads in parallel to deliver significant gains in system performance and cost savings. The 34K cores leverage the 24KE microarchitecture for integrated DSP capability.

Features

- As many instructions as an expert designer needs can be added
- The encoding of the user-interpretable bits in a CorExtend™ instruction is completely up to the user
- The CorExtend block is tightly coupled to the integer execution unit
- The CorExtend block receives the full instruction word and up to two operands from the register file
- Each instruction extension may return one result to the register file
- Local state values can be stored in the CorExtend block
- Pipeline dependencies are always checked for both operand and destination registers
- Only fixed integer instructions are allowed
- Instructions may be single- or multi-cycle
- The CorExtend block is largely independent of the Pro core integer pipeline
- The CorExtend block can stall the integer pipeline if desired
- Software can check if the CorExtend feature is implemented through the configuration register

Pro Series® Family
CorExtend™ capability
development flow

Worldwide Offices

Headquarters
MIPS Technologies, Inc.
955 East Arques Avenue
Sunnyvale, CA 94085
United States
Phone: 408-530-5000
Fax: 408-530-5150
www.mips.com
info@mips.com

MIPS Technologies, Inc. (Oregon)
Beaverton, Oregon
Phone: 503 597-5091
Fax: 503 924-1110

MIPS Technologies (Shanghai) Co., Ltd.
Shanghai, China
Phone: +86 21 6385 8383
Fax: +86 21 5306 0833

MIPS Technologies B.V.
Jhubei, Taiwan
Phone: +886 3 6583 561
Fax: +886 3 6583 563

MIPS Technologies B.V.
Tokyo, Japan
Phone: +81 3 5733 9541
Fax: +81 3 5733 9545

MIPS Technologies B.V.
Halver, Germany
Phone: +49 170 6365 370
Fax: +49 2353 666 920

MIPS Technologies B.V.
Nesher 36841, Israel
Derech Bar Yehuda 53 - POB 12034
Phone: +972 (545) 441 579
Fax: +972 (153) 545 441579



© MIPS Technologies, Inc. All rights reserved.
MIPS, MIPS16e, MIPS32, M4K, 4KE, 4KSd, 24K, 24KE, 34K, SmartMIPS, CorExtend, and MIPS-Verified are trademarks or registered trademarks of MIPS Technologies, Inc. in the United States and other countries. All other trademarks referred to herein are the property of their respective owners.
Printed in the USA. Rev 0306